

MINI

by panconnect•

MINI belongs to **PANCONNECT's** modular range. This panel is suitable for places where drilling is a not preferred option. Installation of **MINI** is easy, just clip the panel from the side of the table and tighten the screws. The holder also safely covers all cabling leading from the panel under the desk. **MINI** is made out of stainless steel and is very powerful in terms of connectivity - **USB-A** together **with strong 60W USB-C**. This panel is produced in 3 colours and customizables sides are possible to be implemented.

PANCONNECT currently offers **3 variants** of panel **MINI** - **MINI BASIC**, **MINI M** AND **MINI XL**. **MINI BASIC** contains only sockets and connector modules for cables without USB charging. Panels **MINI M** and **MINI XL** are fully integrated with **USB-A** and **USB-C** charging and sockets.

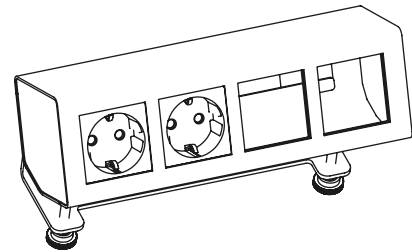

BASIC

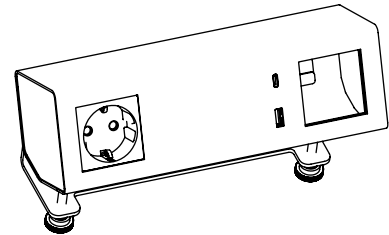

M

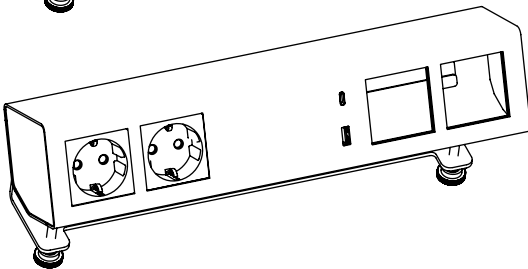

XL

DIMENSION	WEIGHT	MAX. NUMBER OF SOCKETS	MAX. NUMBER OF MODULES	USB-C AND USB-A CHARGING
236 × 101 × 144 mm	2010 g	4	2	×
236 × 101 × 144 mm	2280 g	2	1	✓
345 × 101 × 144 mm	2980 g	4	2	✓

MINI

by panconnect.

BASIC

SIDE VIEW OF THE MOUNTED PANEL

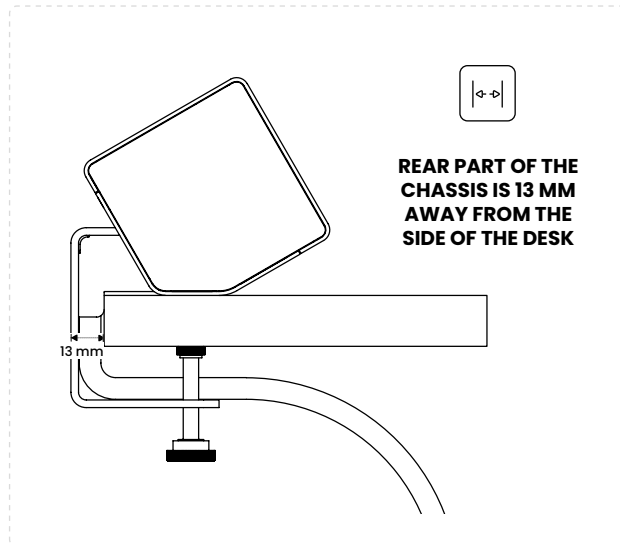

POWER CABLES

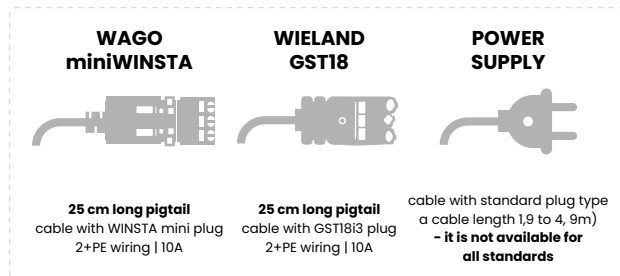

SOCKETS

NUMBER OF SOCKETS: 2-4

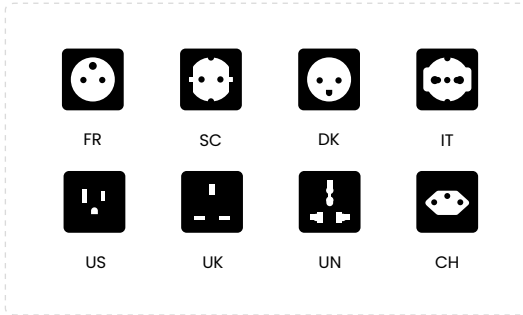

MODULES

NUMBER OF MODULES: 0-2

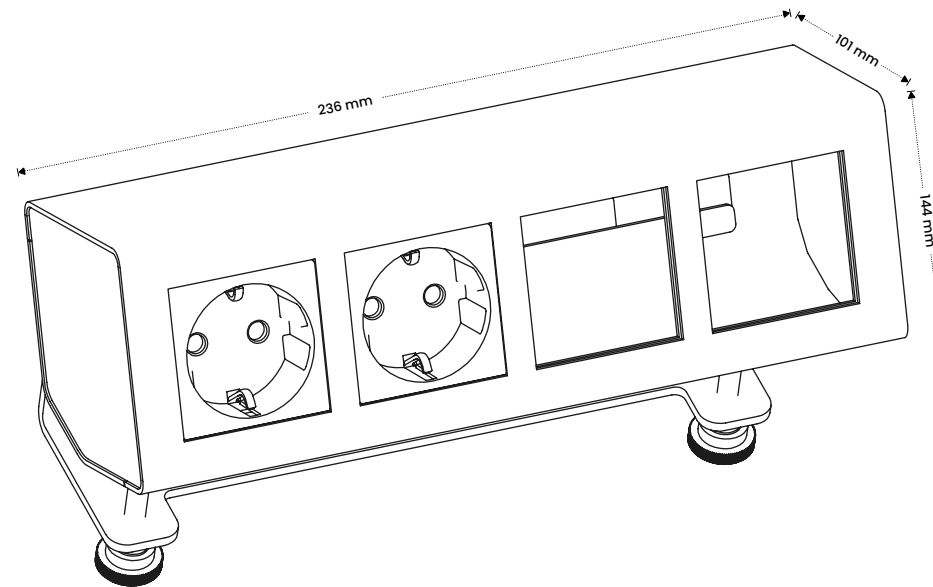
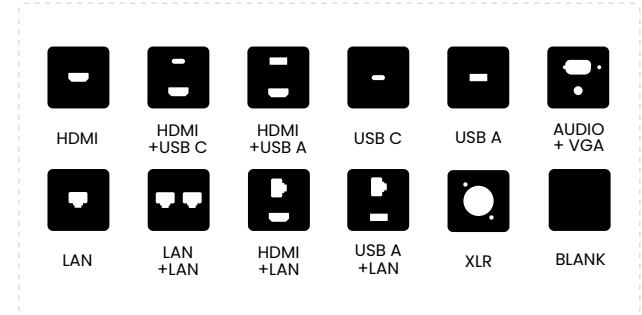

2010 g



PACKAGE CONTAINS

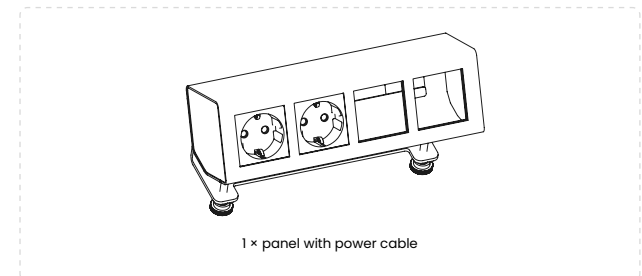

COLOURS



MINI

by panconnect.

SIZE M

SIDE VIEW OF THE MOUNTED PANEL

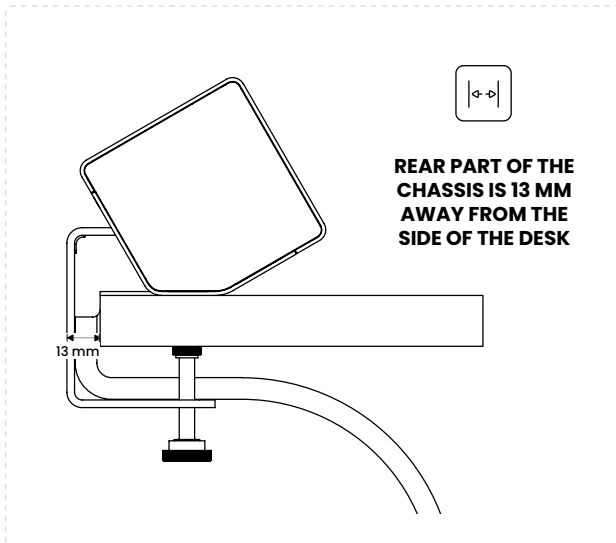

POWER CABLES

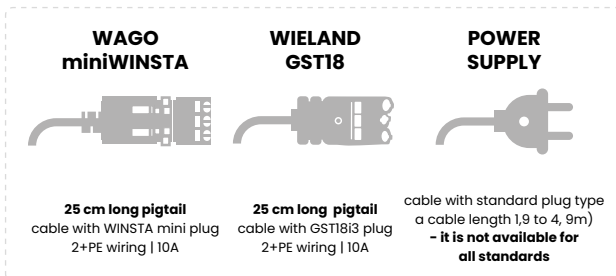

SOCKETS

NUMBER OF SOCKETS: 1-2

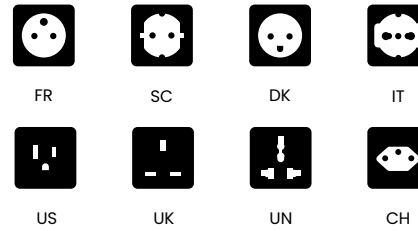

MODULES

NUMBER OF MODULES: 0-1

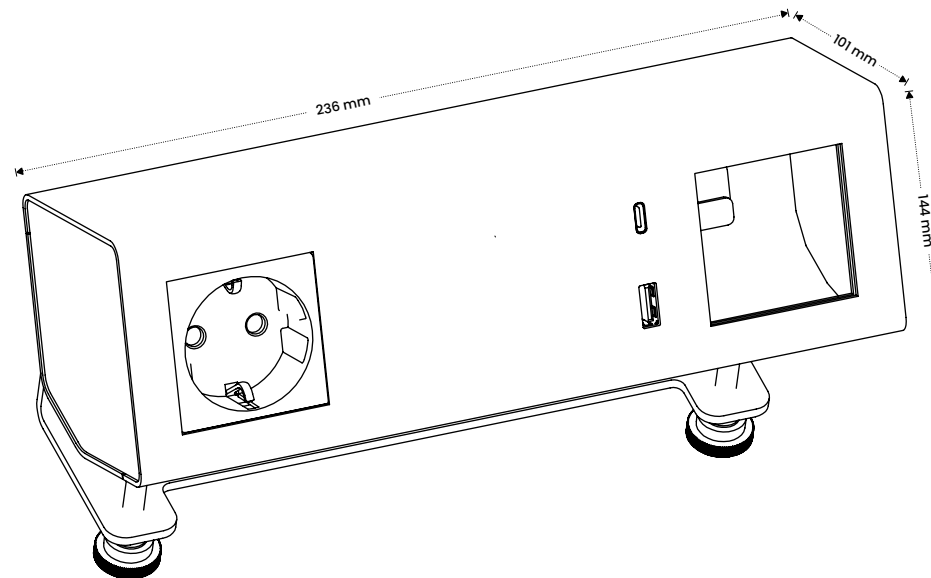
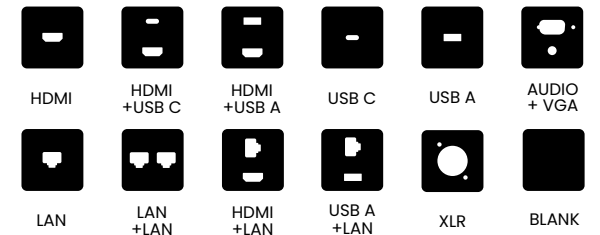

2280 g

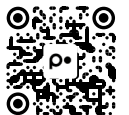

PACKAGE CONTAINS

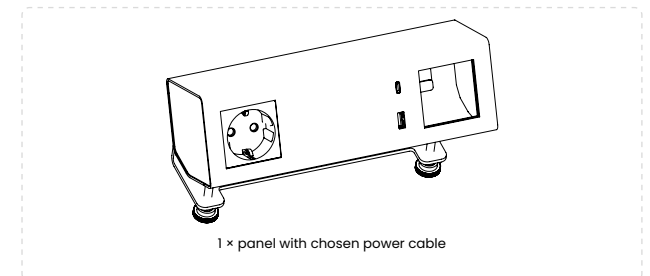

COLOURS



black



white



silver

MINI

by panconnect.

SIZE XL

SIDE VIEW OF THE MOUNTED PANEL

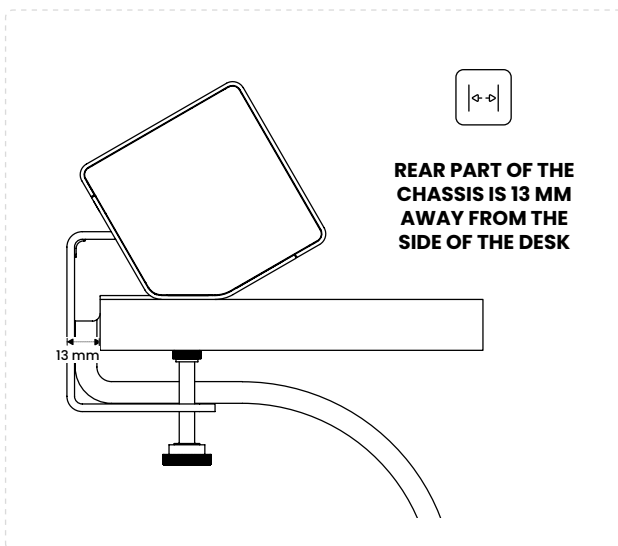

POWER CABLES

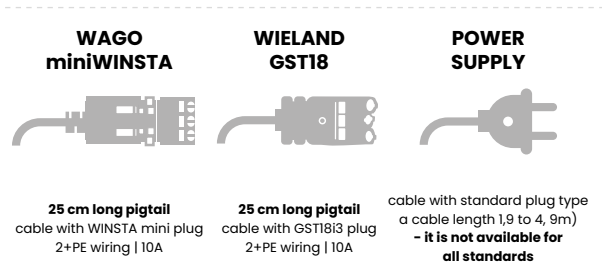

ZÁSUVKY

POČET ZÁSUVEK K POUŽITÍ: 2-4

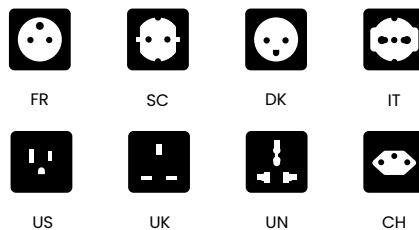

MODULKY

POČET MODULŮ K POUŽITÍ: 0-2

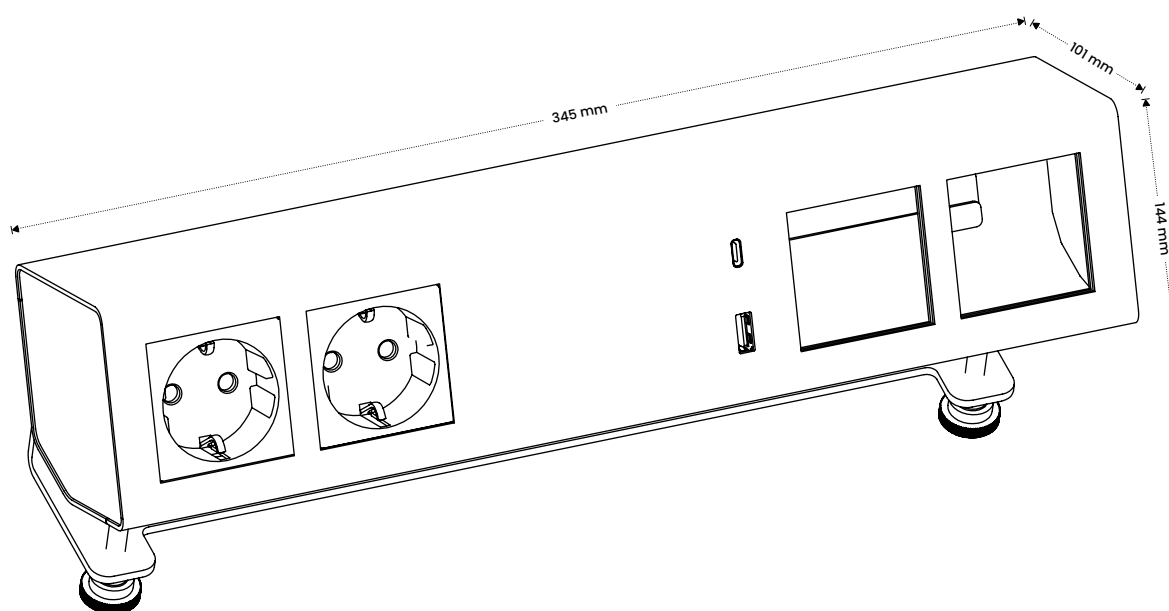
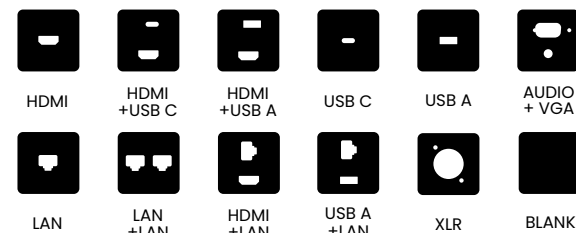

2980 g



PACKAGE CONTAINS

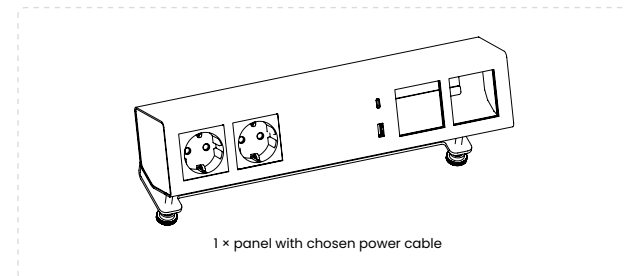

COLOURS



black



white



silver

MODULES

by panconnect.

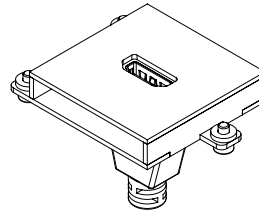

**HDMI
HDMI2.0b**

F/F
4K 60HZ
150mm
gold plated
awg32/22
black pvc

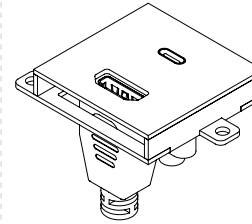

**USB-C 3.2
GEN 2**

M/F
10Gbps
150mm
gold and nickel plated
black pvc

**HDMI
HDMI2.0b**

F/F | 4K 60HZ
150mm | gold plated
awg32/22
black pvc

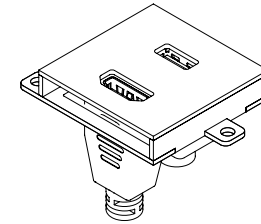

**USB-A 3.0
GEN 2**

F/F
5Gbps | 135mm
gold and nickel plated
AWG 28/28
black pvc

**HDMI
HDMI2.0b**

F/F | 4K 60HZ
150mm | gold plated
awg32/22
black pvc

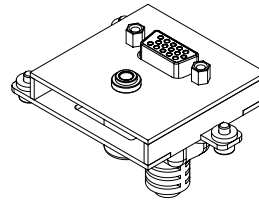

**VGA
DDC2 and EDID support**

F/F
HD
150mm
15pin
black pvc

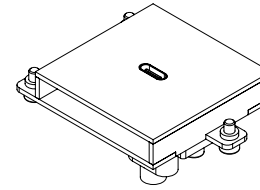

**USB-C 3.2
GEN 2**

M/F
10Gbps
150mm
gold and nickel plated
black pvc

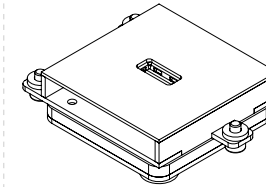

**USB-A 3.0
GEN 2**

F/F
5Gbps | 135mm
gold and nickel plated
AWG 28/28
black pvc

AUDIO

F/F | 3,5mm jack
3 PIN 0,35mm
150mm
goldplated
black pvc

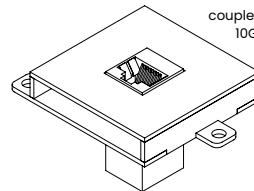

LAN

CAT 6A

coupler RJ45 | up to 500MHz,
10GBase-T | Gold-plated
360° shielded
connection
Fully shielded
metal housing

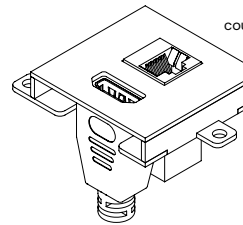

LAN

CAT 6A

coupler RJ45 | up to 500MHz,
10GBase-T | Gold-plated
360° shielded
connection
Fully shielded
metal housing

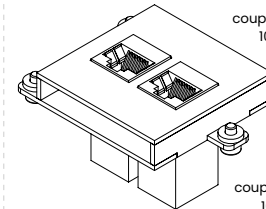

LAN

CAT 6A

coupler RJ45 | up to 500MHz,
10GBase-T | Gold-plated
360° shielded
connection
Fully shielded
metal housing

LAN

CAT 6A

coupler RJ45 | up to 500MHz,
10GBase-T | Gold-plated
360° shielded
connection | Fully shielded | metal housing

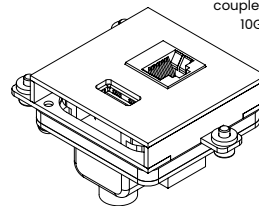

LAN

CAT 6A

coupler RJ45 | up to 500MHz,
10GBase-T | Gold-plated
360° shielded
connection
Fully shielded
metal housing

**USB-A 3.0
GEN 2**

F/F
5Gbps | 135mm
gold and nickel plated
AWG 28/28
black pvc

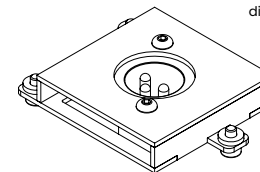

**XLR
SOCKET FEMALE**

16 A
direct 3pin solder-on
25mm
nickled
Black PLA

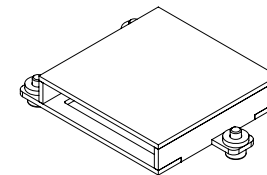

BLANK

PRÁZDNÁ POZICE
PRO PŘÍPADNÉ
POZDĚJŠÍ POUŽITÍ

COLOURS



black



white



silver

SAFETY & RECYCLATION



PANCONNECT declares that panel MINI complies with Low voltage directive 2014/35/EC and EMC directive 2014/30/EU. Testing has been made according to EN 50491-5-1:2010 and EN 50491-5-2:2010 standards.



All products from PANCONNECT are intended for **upgrade** or **recycling** in accordance with the company's policy.



Before the disposal of this panel comes up, please verify if this product can or cannot be upgraded or overhauled. If it's not possible, kindly arrange the disposal in accordance with valid EU directives. This product belongs to WASTE ELECTRICAL AND ELECTRONIC EQUIPMENT (WEEE) category so the disposal is possible only in accordance with this WEEE Directive 2012/19/EU. It cannot be part of the municipal waste.

For more information please check
www.asekol.cz | info@asekol.cz

USB-C SPECIFICATION

PowerDelivery up to 60W

USB-A SPECIFICATION

QuickCharge 3.0 up to 5A

SOCKETS

230V/10A (EU), 110V/10A (US)

INGRESS PROTECTION

IP22

POWER SUPPLY

110 - 250V, 10A

MODULARITY

MODULES

MATERIALS

stainless steel | FENIX NTM | kortexin

DESIGNER

Dominik Hutečka

INSTALLATION MANUAL

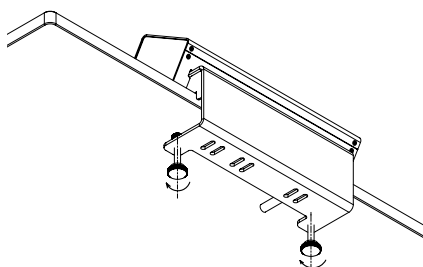
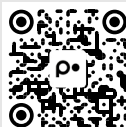

2 MOUNT TYPES BASED ON THE DESK HEIGHT

MOUNT A
10-30 mm

MOUNT B
30-45 mm

No tools are needed for this installation. You need to choose size of the side mount before you order the panel (10-30 mm or 30-45 mm).

- 01** Take the panel of the box.
- 02** Clip the panel from the side of the table (no drilling)
- 03** Tighten the screws.

Designed & manufactured in Brno, Czech Republic.
PANCONNECT s.r.o. | Olomoucká 51, Brno | Czech Republic
www.panconnect.eu | support@panconnect.eu

panconnect